

GSG-9/GSG-10 Semi-Auto Gluer

STREAMLINE YOUR GLUING PROCESS



Regular Slotted Cartons are by far the most widely used type of corrugated box. They are strong, cheap and relatively simple to produce. Many great machines exist in the market today for the production of these boxes.

At Converta Machinery, we sell a wide range of machinery to cater for the production of RSC's in short to large runs. The common complaint in the marketplace seems to be: "Now how do I glue these boxes quickly without spending an amount of money with more digits than my telephone number?"

Hot melt gluing systems have long been a standard method of gluing corrugated boxes, but there are a great many drawbacks in using a hot melt system. The price of the glue is very high and the box you're left with is often not even square. There has to be a better way...

We at Converta Machinery have the answer for you and offer a competitive price and simple operation to put an end to your gluing dilemmas. Keep the cost of your gluing process down! PVA and EVA are far more economical than hot melt glues. 'The Semi-Auto Gluer' also possesses a squaring section so you can say goodbye to crooked RSC's forever. It only takes one person to feed and operate this machine and one person to stack the bundles that are created. With the incredibly competitive price tag and the gains that stand to be made in labour... Ask yourself: Can you afford not to have this machine?

Facts & Features:

Adjustable Gluing Head

Squaring Hopper

Compact Size

Motorised Feed Table

Bundle Counter

Short Set-up Time

Up To 2500 Sheets Per Hour



Unit 3, 31 - 33 Hume St
Huntingdale, Vic 3166

Email: converta@converta.com.au

Ph: +61 3 9545 5455

Fax: +61 3 9548 7077

GSG-9/GSG-10 Semi-Auto Gluer

Specifications

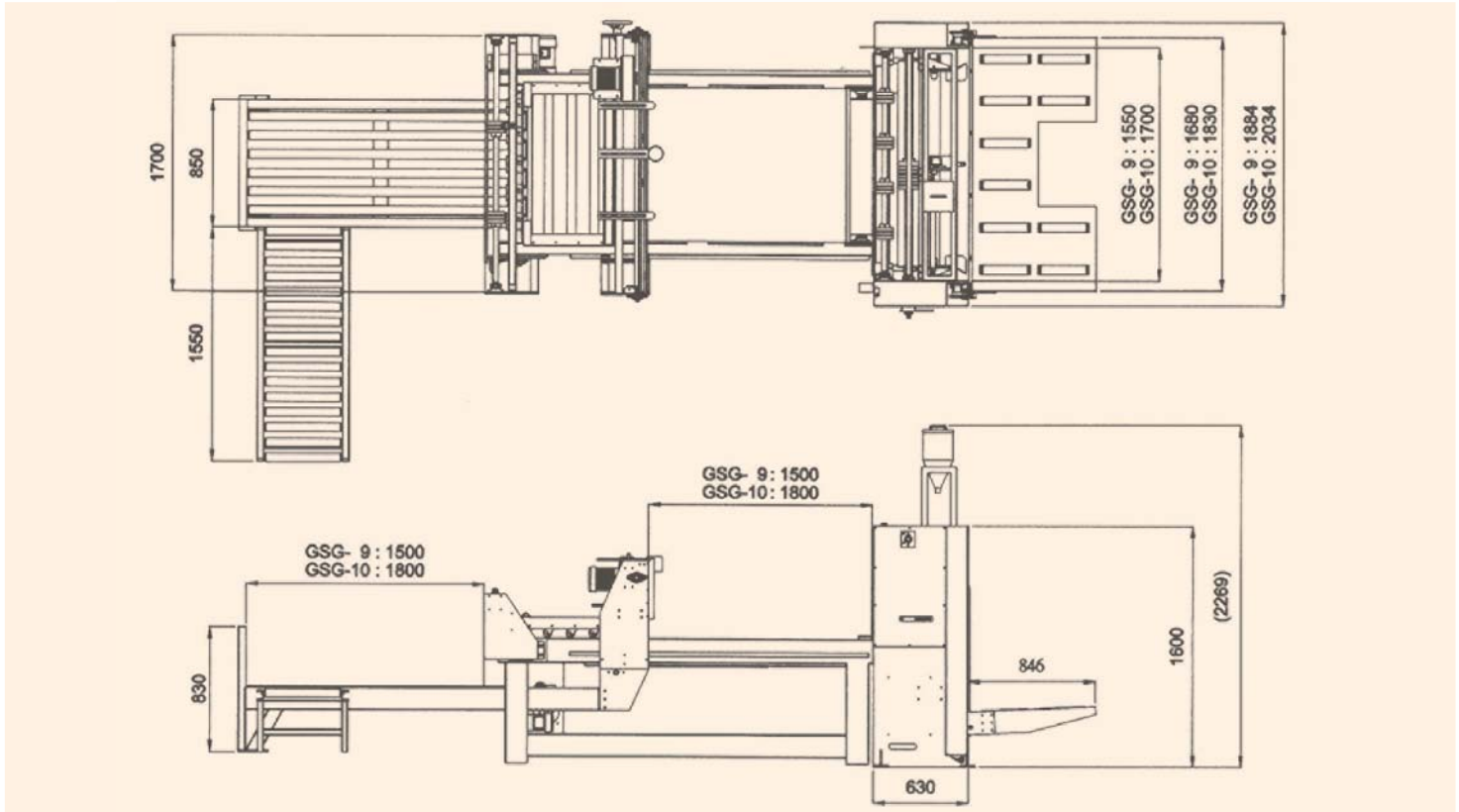

Type	GSG-9	GSG-10
Speed	40–50 sheets/min	
Max. Sheet Size (mm)	2800(w) x 1500	3000(w) x 1800
Min. Sheet Size (mm)	525(w) x 240	
Max. Glue Lap (mm)	45	
Stack Height (mm)	1000	
Total Power	4 HP	
Adhesive	Resin	
Gross Weight	2380 Kg	2550 Kg

Specifications and design may be changed without prior notice



- The Adjustable Gluing Head enables just the right amount of glue to be placed on the carton to achieve the perfect glue line.
- The motorised feed table allows the working surface to be easily kept at a comfortable working height for continuous feeding.
- The Squaring Hopper squares up the cartons after gluing and stores them in the hopper long enough for the glue to hold before being automatically transferred into the Counter Ejector.
- Counter Ejector allows for cartons to be bundled into pre-set quantities before being automatically ejected onto the conveyor. No more manual counting and bundling.
- The compact design means that it can be placed in a convenient position without taking up valuable floor space.